

ELDEANews

May 2025

INTERESTING STUFF COMPILED BY WADE

Please Welcome your new Dock Neighbor!

Ahoy and welcome to Eldean Shipyard! We are thankful to have a fantastic group of boaters on our docks and this year's new slip members will certainly be another great addition. Heather will be giving a marina tour to all of our new boaters to provide info about our marina and the nearby attractions. Additionally, if you are new to our marina and have questions, don't be shy, just ask one of your dock neighbors or stop by our Shipstore and ask our crew.

Our Summer Crew...

We are very happy that Leslie is returning for her 4th summer as our Shipstore Manager! Lauren, who in her 5th summer working in the Shipstore, will be heading up our summer crew. Additionally, there will be a few other new faces in the Shipstore this summer including Abby, Maddie, Jonah, Brayden, and Mckenna (2 are twins, can you identify them?). Riley will be our new pool attendant this summer. We are excited about our summer staff and are looking forward to a great summer season. Our crew is happy to assist you! Just ask.

YoChef's Café is Back!



Last Season we were excited to offer food and drinks at the pool clubhouse for the 1st time. The food was really good and waterside dining can't be beat! YoChef's Café is planning on returning for this summer and offering burgers, grilled salmon, chicken wraps, and more. Please remember, food is not allowed on the pool deck.

Last Season we were excited to offer food and drinks at the pool clubhouse for the 1st time. The food was really good and waterside dining can't be beat! YoChef's Café is planning on

The 2025 Party Schedule - Save these Dates

Our summer dock-parties will be held on the following dates at the Z-dock and playground picnic areas. More information will be emailed and posted in July.

C, D, E, R Docks & Buoys 6:30 pm, Saturday, July 26
Z, A & B Docks 6:30 pm, Saturday, August 9



Eldean Shipyard 50th Anniversary Party May 2023

Memorial, 4th of July & Labor Day Holidays

The Eldeans will be firing up the grills again! Stop by the picnic tables at the playground for grilled salmon, hot dogs, chili-dogs, & brats on Friday the 4th of July, & Sunday afternoon of Memorial and Labor Day Weekends - Compliments of the Shipyard! **We will be cooking from 12-2:30 (or until the food is gone).**

NEW Parking Stickers this Year!

Everyone will need a **green parking sticker this year.** If you don't have a green sticker on your car, you may find a big, no-parking sticker stuck on your windshield. ***Parking is an issue in Macatawa, so please comply!***

There is still time for you to help. ACT NOW!

As you may know, Eldean Shipyard (“Gator Properties”) has an application in front of Laketown Township to allow for our Parking Lot at the Gravel Parking Lot by Z-dock and to allow for boatlift and trailer storage in that area (we have removed the proposed pickle ball court recreation building from the original application).

Our gravel parking lot has never officially been permitted as it is located in residential zoning and it must be changed to commercial zoning to properly permit this parking lot. Without this rezoning, parking may no longer be allowed nor the storage of our customer boatlifts in this area. As we know, all boaters like to have convenient parking! Additionally, this parking lot also allows the marina to rent to Macatawa Park house guests for their overflow parking helping ease parking congestion on the streets around the marina.

We had good news earlier this year, as the Laketown Planning Commission voted to support this request! However, the Laketown Board of Trustees still must approve the request before it is final. And, at this recent April meeting, the Board of Trustees tabled the request. There were two major pushbacks/concerns that they would like us to address:

1. It was said that our boatlifts stink from the Zebra Mussels: This is very much an exaggeration that was started by a neighbor. The smell is not an actual problem. One trustee noted that he walked past the lifts and didn't smell anything either. However, to address this concern, we are offering to remove the majority of muscles from the lifts before storing in the lot. Additionally, we will offer to add some privacy fencing and privacy trees.

2. The Supervisor of the Board of Trustees believes that there should only be houses built on this parcel and the property should not be used for marina services. Please help us convince the Supervisor that our marina uses are much more important to the community than building a couple of houses on this property. The Township Board should be looking at all the positive aspects that come from these boating services and by approving this proposal they are voting to facilitate boating access to Lake Macatawa and Lake Michigan for their residents and other boaters in our community.

Please help me in this rezoning request as boaters cannot afford to lose boating access and services! Once services are lost and/or homes are built, the services rarely come back. Please write to help protect your water access and the boating services like parking and lift/trailer storage that are required!

This [is a link](#) to the original notice that Laketown Township provided last fall.

This [is a link](#) to the recent article on the front page of the Holland Sentinel.

If you could please send a letter of support to the Laketown Township Board right away or come to the hearing and express your opinion on Wednesday, May 7th (5pm at Laketown Township Hall).

Send to:

Laketown Board of Trustees, 4338 Beeline Rd. Holland, MI 49423 or email to: office@laketowntwp.org. To make it easy, if you click on this email address, an "in-favor of" message will populate. **Just sign your name and add your mailing address.** However, if you have time, a more personalized message is always appreciated and notice by the board.

I would be happy to discuss if you have any questions or comments. I would appreciate your support!

Thank you,

Wade

Boat Service Team...

Additionally, our service team of Heather and Scott are here to make things better when you have problems with your boat or want something to make boating better. Do you need boat washing this summer? The email address for service work requests has not changed and you can contact them here:

Scott at boatservice@eldean.com

Heather at service@eldean.com

Both Scott and our lead mechanic, Randy, went to ABYC training this winter to polish up on their skills and expand their knowledge in our industry. Additionally, we purchased a bottom peeler tool to help with stripping boat bottoms when it's time for a complete redo of the bottom.

New Boat Transporter!

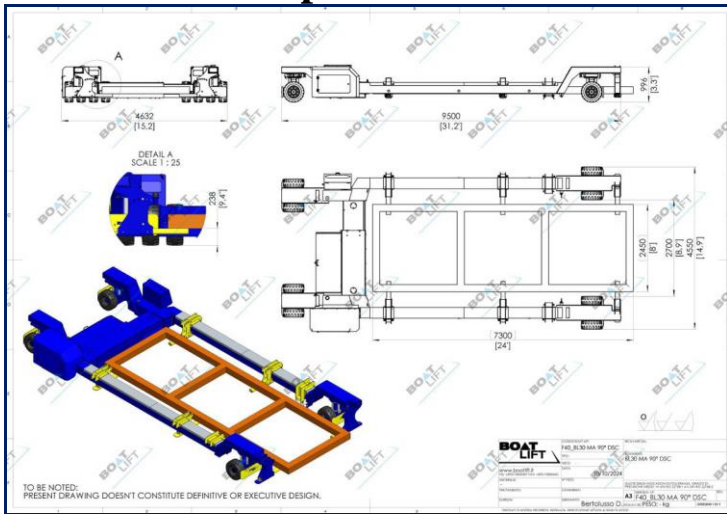

We are very excited for the arrival of our new, 30-ton **Boat Lift**, boat transporter! The new, remote-controlled machine, just arrived from Italy, & was assembled. We are getting oriented with it & begin bringing boats from our buildings to the haulout for this year's launch cycle.



Our new 30 Ton, Boat Lift brand, Transporter

Would You Like Piling Caps Installed?



If you would like to add white piling caps to your slip, we will install them at the discounted price of \$25/piling (normally \$30-\$35 w/o install). We think they will be a benefit for years to come (they remain with the marina if you leave). The piling caps should help reduce the amount of bird droppings on and around your boat.

[Email me](#) if you would like them installed at your slip.

Do you need Internet Access?

A Seasonal Wi-Fi Subscription is \$95. Please [email Wade](#) to set up your Wi-Fi access. Many of you have already signed up and I have already sent you an email with your subscription information. For problems with your Wi-Fi this summer, please email computers@eldean.com or stop by the Shipstore and let us know.

WATER LEVEL UNCERTAINTY...

The water levels have dropped a bit! I anticipate the water level this summer will be about 10" lower than last summer. 5 years in a row of lower water isn't good news. We would like more stable levels from year to year without dramatic swings from highs to lows.

To see the water data from the USACE:

[The Lake Michigan Monthly Forecast Bulletin](#)

Lower Water Dock Issues:

As the water level is going down, our docks that were rebuilt for the all-time-high water levels may be a little high/tall for your boat. We are continuing to lower a few docks at our expense that were necessary and also a few others for convenience that we split the cost with the boater. If your dock is too high to board, the options are:

-Install a ladder: Buy or Rent. For a rental ladder it is \$95 and includes installation.

-Hire us to lower the dock. Your dock neighbor will have to agree too (and possibly split the cost with you). If the old support structure is still there, then it will be much quicker and less expensive.

Eldean Shipyard, 2223 South Shore Drive, Macatawa, MI 49434

616-335-5843 fax: 616-335-5848 www.eldean.com email: wade@eldean.com

- New customers please take note -

For marina information regarding news, amenities, events, suggestions, and policies: Go to www.eldean.com/news, [Calendar of Events](#), and also Click on the "[More Fun Stuff](#)" heading (left side) for additional info on marina services and nearby attractions.

Pick up your Keys

Pool and Head Keys are each available in the Shipstore. Each key has a \$20 deposit that is refunded when you return the key.

Parking Stickers

If you haven't already, please fill out your parking form and we will mail you up to 3 parking stickers (\$20 each). This is the new green oval sticker. If you purchase a new car, *just bring us your old sticker* and we will issue a new one at no charge. The parking stickers are usually updated every 5 years, so you do not need new stickers every year. Day/weekend passes will be available for your guests at no charge. On busy days, guests parking will be directed to building #7.

Your Boat and Dockbox Keys, please: We need to have a spare set of your keys and/or combination to your boat in order to move the boat in the event of an emergency and for winter storage. When we are doing dock work, we may need to remove the dockbox.

Tie up your boat on all sides: On the day that you arrive to your slip, it may be a calm and peaceful day. Unfortunately, storms come and go, and during wind and storm events it is important that your boat is tied up with many lines and all sides of the boat. [Click here](#) for more information on tying up your boat properly.

Pool Rules – 5 People MAX in your group and the boat owner/family member must be present (Do not give your keys to neighbors or friends). [Click here for More of the Pool Use Policy](#). Also, Glassware/bottles & Food are NOT allowed around the pool.

If you leave with your boat for 48 hours -

When you are not using your slip we make it available for transient boaters to rent on a nightly basis. If you go cruising or remove your boat from the slip, for any reason for 48 hours or more, *you are required* to let us know that you will be vacating the slip. Please let Leslie in the Shipstore know the date of departure and return before you head out. You can stop in the Shipstore or email Leslie at store@eldean.com.

Lobster Truck?



Welcome Cousins Maine Lobster Food Truck! Yes, this is as seen on *Shark Tank*, *Good Morning America*, *The Today Show*, and more. We are thrilled to announce that their newest food truck will be headed to Macatawa to offer us a lunch and delicious lobster meals this summer! Lobster Tails, Rolls, Tots, Bisque and More!

Saturday, June 14, 11-2:30

Saturday July 19, 11-2:30

Saturday August 23, 11-2:30

Additional Summer Spaces...

Many of you have toys, dinghies, kayaks, SUP, etc that make a day at the marina more fun and enjoyable. We do have room available for some of your toys, but since space is at a premium, we do have a fee for them:

-*Kayak Rack* - \$100 (only \$50 on top rack)

-*Dinghy Spot* - \$100 small, or \$150 Larger

- *SUP/paddleboard Rack*- \$35

PWC/Dingy Boatlift...

If you would like a boatlift for your dinghy or PWC, I have a couple of lifts available for this summer because of late cancellations. For an existing slip customer the lifts are discounted and rent for \$2035 - \$2195 (\$3295 - \$3495 for non-slip customer).

Pops at the Pier – 2025 Scheduled!

The annual Pops at the Pier concert by the [Holland Symphony Orchestra](#) has been scheduled for Thursday, June 19th. It's an unforgettable evening of music, food, and fun with the [Holland Symphony Orchestra](#). Concert tickets are available through the Holland Symphony website. There will be food vendors, so bring your appetite to enjoy great food and music!

This year's main program is "The Music of Judy Garland" and [this is the promotional flyer](#).

Thursday, June 19, 6:00 to 9pm, Tickets \$20-\$37

Location: The Eldean Boat Shed #3



Tickets available at Symphony Office, 616-796-6780

Progress on Stopping Asian Carp

"The U.S. Army Corps of Engineers, Rock Island District, awarded the first construction contract for the Brandon Road Interbasin Project on November 27. The \$15.5 million contract was awarded to Miami Marine Services for site preparation and riverbed rock removal for the engineered channel. Miami Marine will partner with Michels Construction, Inc. of Milwaukee, Wisconsin, for completion of this contract.

This project, which is a partnership between USACE and the States of Illinois and Michigan, is part of the first of three construction increments for the estimated \$1.15 billion project designed to prevent the upstream movement of aquatic nuisance species into the Great Lakes." [View Full DNR Release Here](#)

Social Media Connections...

To follow Eldean Shipyard on Facebook, like [Eldean Shipyard and Marina](#).



Kris Eldean has taken to Instagram to share interesting marina photos and happenings. Go to:

www.instagram.com/eldean_shipyard

We are now an LMSRF Sponsor!

[The Lake Michigan Sail Racing Federation](#) (LMSRF) is a not-for-profit charitable association of individual Yacht Clubs, sailing groups and individual sailors located in the states of Illinois, Indiana, Michigan, and Wisconsin.

LMSRF promotes sail racing competition on Lake Michigan for Offshore, Youth, and Day-racing One Design sailors. It works to grow the numbers of boats on starting lines. It also provides racing information through its newsletters, e-mails, and its web site as well as educational programs.

The organization supervises the functioning of racing, rating rules and provides an Appeals Committee for the next step in the progression in the US Sailing Appeals process.

In addition, the LMSRF Donation Program, Endowment Fund, and Grants-in-Aid program provides financial assistance to promising sailors in their educational and competitive efforts.

Looking for Race Crew?

Do you need racing crew or are you looking for a boat to crew on? Check out [Crew Finder and Boat Finder](#), a system supported by the Lake Michigan Sail Racing Federation (LMSRF). The LMSRF stated, "After years of seeking a suitable platform, the Lake Michigan Sail Racing Federation Board has a new Crew and Boat Finder. We are grateful for the development of 'Rail Meets' and believe this comprehensive system will provide for the needs of our racing skippers and crews."

There are only a few from our area signed up at this time, but this sounds like it has the potential to be great solution for connecting Captains with Crew!

Dockbox Maintenance....

“A”-dock received special treatment over the winter with all of its dock-boxes repaired and painted, the dock power-washed, and the boxes reinstalled. We intend on continuing with this program on a yearly basis and are planning on reviving the B-dock boxes this winter and also giving the dock a good power washing when the boxes are removed. And remember, if the pulpit of your boat pokes a hole in the dock box we will be sending you a repair bill, so make sure that you have a spring-line in place that won't allow your boat to hit the box.

A Stamp Riddle (artwork by Sue Henry)



Fish + Sandpiper + Lighthouse + Sailing = Eldean Shipyard!

We are a MI Clean Marina!

To help keep our waters clean and provide outdoor opportunities for kids, Eldean Shipyard supports the Michigan Clean Marina Program, the Macatawa Greenway & the Outdoor Discovery Center. Let's keep our water clean for future generations!



Free Great Loop Memberships!

We are seeing more and more “loopers” come through the marina on their cruise through the Great Lakes. Some of the boats stop and winter store with us before they head south again in the spring. This is an amazing journey that takes one through very remote river locations as well as large cities on the shores. I've made about 98% of the loop in a few different trips, only to have missed the west coast of Florida.

Eldean Shipyard has sponsored the America's Great Loop Cruisers' Association (AGLCA), and with our sponsorship I have 15 free memberships left still that I can give out to any of our interested slip or storage customers. Please let [me know](#) if you would like one.

This year marks the Bicentennial of the Erie Canal.

If you are on the Loop this year, Boat US is sponsoring this 2025 Bicentennial celebration and describes the Erie Canal as “a premier recreational boat waterway, with historic infrastructure that mostly still runs on simple waterpower, offering a ribbon of navigable canals, locks, rivers, and lakes across upstate New York connecting the East Coast with the Great Lakes and Canada that provide a cruising experience found nowhere else in America. The villages, towns, and cities that line her shores offer a wealth of tourism opportunities for visiting boaters.”

I've had the pleasure of a dozen or more boat delivery trips along the Erie Canal. We generally work dawn-til-dusk, so I saw a lot in a short time, but I didn't get to explore much as we would only stop for the night. I would love to go back through the system on a pleasure cruise and take more time while in port to explore.



Interesting Ice Formations this winter!

Looking Good and Making Improvements!

There is a lot that goes on in order to get ready for summer. This year we are painting dock boxes, power washing docks, paving parking lots, updating gardens, replacing pool coping pavers, **upgrading our pump-out**, replacing rotted pilings, lowering docks, and adding boatlifts. Whether it's materials, utilities, fuel, or labor, it is certainly costing us more to provide the same marina facilities and boating experience than it did just a few years ago; we are committed to our maintenance programs and keeping Eldean Shipyard one of the finest marinas on the Great Lakes!



New Pump-out!

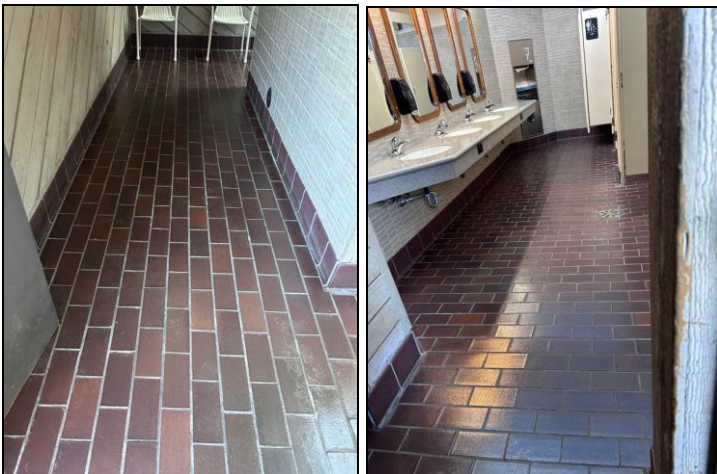

Jessica got the bathroom tiles very clean and shiny!

The Weather Buoys...

Thanks to new technology, you can now get up-to-date wind speed, water and air temperature, wave height and more, by texting a buoy — Yes, text a buoy! By simply texting 866-218-9973 with the ID of one of the 68 buoys that are part of the Great Lakes Observing System. The Holland/Port Sheldon Buoy ID is 45029.

There are 20 weather buoys on Lake Michigan providing real-time critical data to fisherman, sailors, boaters and even beachgoers (rip current potential for beach activities). An index of all the Great Lakes buoys is at <https://glbuoys.glos.us/>. The Port Sheldon location has been one of the most active buoys on Lake Michigan.

Our Port Sheldon Buoy depends 100% on donations and advertising for funding. If you would like to make a donation or have any questions, please contact Brad Stephenson at brad.stephenson32@gmail.com or (330) 495-9555 and Bill Sikkel at bsikkel@sikkellaw.com or (616) 836-7504.

Plan Ahead for Cruising...

The last few seasons have brought many more boats to Lake Michigan and our great harbors. But that means dockage space is tight, and arranging a transient reservation will be more difficult. You will want to plan ahead and call for reservations. If you already have plans to take a trip or take the boat away for some reason, please let Leslie (store@eldean.com) know the dates of your trip so that she can help a visiting boater reserve a slip here in Macatawa. **When you leave, your slip becomes available for nightly rental and you are required to let us know if you will be away from the slip for 48 hours.** We already have a waiting list of transient boaters and we need your cooperation in order to provide them dockage. And hopefully, when you go cruising, your destination will be trying hard to find you a slip too!

Eldean Shipyard, 2223 South Shore Drive, Macatawa, MI 49434

616-335-5843 fax: 616-335-5848 www.eldean.com email: wade@eldean.com

What will we do today?

The MAC Adventure Sports Rental Trailer will soon be open for business. MAC Adventures, LLC is excited to return in 2025 and offer adventures in water sport rentals. MAC Adventures is providing paddle board, inflatable/RIB-boat, kayak and pontoon boat rentals. High quality and comfortable equipment with outstanding service is what you will get when you rent from MAC Adventures. Located at Eldean Shipyard, West Michigan's premier marina, rentals have easy access to Lake Michigan as well as Lake Macatawa.



You can usually find them in their rental trailer (Weekends in May from 10am to 6pm and June-Labor Day 9am to 8pm.). Or they may be helping customers with rental boats at slips R-5, R-6, R-7, & R-8. For all the Boat, Bike, SUP, & Kayak rental info, go to:

Website: www.Macadventuresllc.com

Phone: 616-377-8322

Email: Info@macadventuresllc.com

Electric Vehicle Chargers

Relax at the Pool while Charging your Battery!



As manufacturers are switching over to electric vehicles, we installed a couple of JuiceBox Pro 40c electric vehicle chargers

at the marina. The chargers are located outside the pool clubhouse and also inside building #1. Payment for using the car chargers is made through an App after scanning the QR code on the charger. ***Slip Holders will not be charged the additional \$10 parking fee if you tell us in advance that you will be using the charger and [provide Wade](#) with your name and email address for setup.*** Your information will be added to the charging payment system so that you receive the lower rate. Anyone from the public that stops by to use them will be charged the higher rate. Some of the power will be generated from our new solar panels above building #1, so this is a very green system!

News from Holland Yacht Sales



Holland Yacht Sales

If you're looking to make a boating change or have any questions please don't hesitate to call or stop by my office in the Shipstore.

Have a Great 2025 Season!
All the best!

Henry DeJong,

E-mail: hysinc@gmail.com

Office: 616-335-3144 Cell: 616-443-1435

[Click here for my website on Yacht World](#)

FUEL YOUR
PASSION

DIESEL

GASOLINE

VALVTECT MARINE FUEL DIESEL

VALVTECT MARINE FUEL GASOLINE

POWERING YOUR PASSION FOR THE OPEN WATER

IMPROVES FUEL ECONOMY

MINIMIZES POWER & PERFORMANCE

REDSIDES CORROSION CAUSED BY ETHANOL

STABILIZES FUEL FOR 2 YEARS

SAVE 10¢ PER GALLON

Click image for more info

Eldean Shipyard, 2223 South Shore Drive, Macatawa, MI 49434
616-335-5843 fax: 616-335-5848 www.eldean.com email: wade@eldean.com

Voluntary Coast Guard Inspections

The Coast Guard Auxiliary will be here on **June 7th (Z, A, & B Docks) and June 14th (C, D, & E-docks)** to perform boat safety inspections. If you are interested, please let [Leslie](#) know in the Shipstore, ½ hour appointment times are between 9-11:30 and 1-2:30. After passing an inspection, you will receive a 2025 "Safety Check Decal". **Boaters who have a "Safety Check Decal" displayed on their boat, should be free from random stops by marine patrol boats.**

Take a Boater Safety Class?

Please let [Leslie](#) in our Shipstore know if you and/or your children are interested in taking a boater safety class and earning a Boating Safety Certificate at Eldean Shipyard. We may be able to hold a class here if there are enough people interested.

From the MDEQ: In Michigan, boaters born after June 30, 1996, must have a boating safety certificate to operate a boat, and boaters born after Dec. 31, 1978, need a boating safety certificate to operate a personal watercraft ([click here for more details](#)). "If you're on the water operating a boat, or even a canoe or kayak, it's your responsibility to do so safely," said Lt. Tom Wanless, DNR Law Enforcement Division. "We strongly encourage new boaters to take a boater safety course, so they are aware of the dos and don'ts of the water. Even if you have been on the water for years, it's important to refresh yourself on the latest regulations." The DNR offers boating safety education as a self-paced, online course and as a traditional classroom experience.

General Boating Safety

The Michigan Boating Industries Association (MBIA) created this [infographic](#) to help convey some boating safety basics. If you are new to boating safety, [this is a must read](#).

Not another Knot Guide...

However, this time it is a live-action knot guide! Power & Motor Yacht has videos of Capt. Bill Pike performing a few tricks, and tying knots too. [Click here for the videos](#).

1st Swimming Lesson!



Our grandson Archie is having a great time at his first swimming lessons. The swim coach is helping him be comfortable in and around the water. I'm betting we have another boater and water enthusiast in our family! Get the young ones in your family swimming early so that they will be more comfortable and safe around the water.

Learn to Sail Programs...

Visit www.lmsrf.org, then mouse-over "Learn to Sail" on the top of the page and choose from the drop down tabs.

Sailing Charters

Deeplake Ventures will be offering sailing charters out of Eldean Shipyard for their 15th consecutive season.



Charters are captained by Jeremy Smith and are typically 2-4 hours in length on evenings and weekends. The GIG 'EM II is a 2000 Catalina 28 MKII designed with a large cockpit and modern amenities for passengers.

Feel free to contact Captain Jeremy if you are interested in a charter or for captain services on

your current or future sailboat including instruction, delivery, or consulting. :www.deeplakeventures.com.

This Just In [Stock]

This year's clothing selection is arriving in the Shipstore. We brought back a few favorites this year!

